

Guarantee card
Garantiekarte
Carte de garantie
Certificato di garanzia
Tarjeta de garantía
Garantiekarte
Certificado de garantía
Garantibevís
Garantibevís
Takuutodistus
Garantibevís
Certificat de garanție
Záruční list

Garancialevél
Karta Gwarancyjna
Πιστοποιητικό εγγύησης
כתב אחריות
Garanti sertifikasi
Záručný list
Гарантійний талон
Гарантійний сертифікат
Garancijski list
شهادة الضمان
保修证书
ضمانتنامه

Stamp and signature of dealer
Stempel und Unterschrift des Händlers
Cachet et signature du commerçant
Timbro e firma del rivenditore
Sello y firma del proveedor
Stempel en handtekening van de handelaar
Carimbo e firma do revendedor
Selgerens stempel og underskrift
Återförsäljarens stämpel och namnteckninge
Myyjän leima ja allekirjoitus
Forhandlerens stempel og underskrift
Eladó pecsétje és aláírása
razítka a podpis prodeje
Tampila i semnătura vânzătorului
Pieczęć i podpis sprzedawcy
Σφραγίδα και υπογραφή του πωλητή
תאריך קניה
Satıcının mühür ve imzası
Razítka a podpis predajca
Печатка і підпис продавця
Печать и подпись продавца
Peçat i potpis dobavljača
ختم و توقيع البائع
مهر و امضای فروشنده

CONIX

Type 641.02

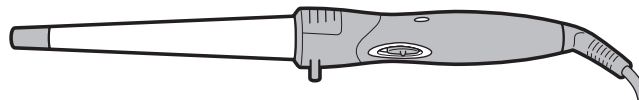

INSTRUCTIONS FOR USE

00060606-05/15

Distributed by Ligo Electric SA - 6853 Ligonetto / Mendrisio - Switzerland
Valera is a registered trademark of Ligo Electric S.A. - Switzerland



EN	Conical ceramic curling iron Translation from original instructions	4
DE	Konischer Keramik-Lockenstab Übersetzung der Originalanweisungen	7
FR	Fer à friser céramique conique Traductions à partir des instructions d'origine	10
IT	Ferro arricciacapelli ceramico conico Istruzioni originali	13
ES	Plancha rizadorora cerámica cónica Traducción de las instrucciones originales	16
NL	Keramische conische krultang Vertaling van de originele instructies	19
PT	Ferro de encaracolar cerâmico cónico Tradução das instruções originais	22
NO	Konisk krølltang i keramikk Oversettelse av original bruksanvisning	25
SV	Konk, keramisk locktång Översättningar från originalinstruktioner	28
FI	Kartionmuotoinen keraaminen kiharrusrauta Alkuperäisen käyttöohjeen käännös	31
DA	Konisk keramisk krøllejern Oversættelser fra oprindelige anvisninger	34
HU	Kúpos kerámia hajsütővas Az eredeti utasítások fordítása	37
CS	Kónická keramická kulma na vlasy Překlad originálních pokynů	40
RO	Drot conic din ceramica pentru ondulat părul Traducerea instrucțiunilor originale	43
PL	Ceramiczna lokówka stożkowa Tłumaczenie oryginalnej instrukcji	46
GR	Κεραμικό κωνικό σίδερο για μπούκλες μεταφράσεις από τις αρχικές οδηγίες	49
HE	הוראות שימוש למסלול שיער דגם	52
TR	Konik seramik saç kıvrırma maşası Orijinal talimatların çevirisi	55
SK	Teplovzdušná kulma Překlad z originálního návodu	58
UK	Щипці для завивки керамічні конусні Переклад з оригінальних інструкцій	61
RU	Плойка для завивки волос конической формы с керамическим покрытием Перевод с оригинальных инструкций	64
SR	Keramički aparat za kovrdžanje kose sa konusnim valjkom Prevod sa originalnog uputstva	67
AR	صفحة كي لتجديد الشعر من السيراميك المخروطي ترجمة من التعليمات الأصلية	70
ZH	锥形陶瓷卷发棒 翻译自原文说明	73
FA	بیگودی سرامیکی مخروطی مجموعه ماشین موزنی حرفه‌ای	78

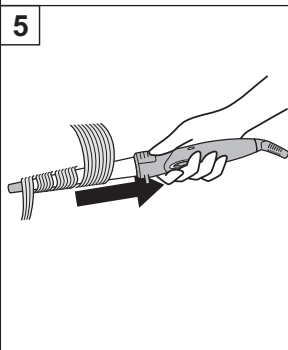
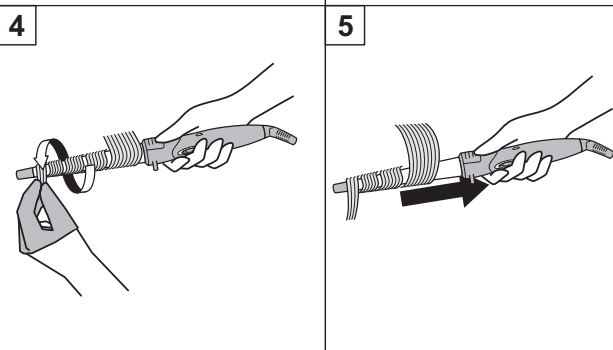
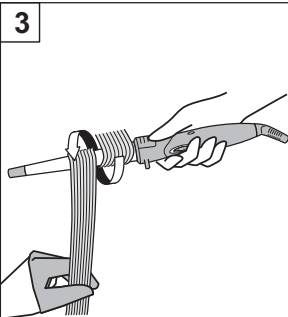
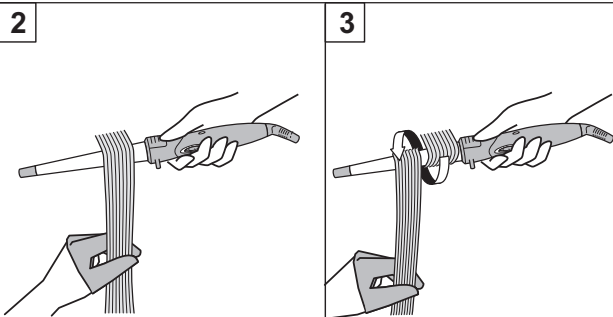
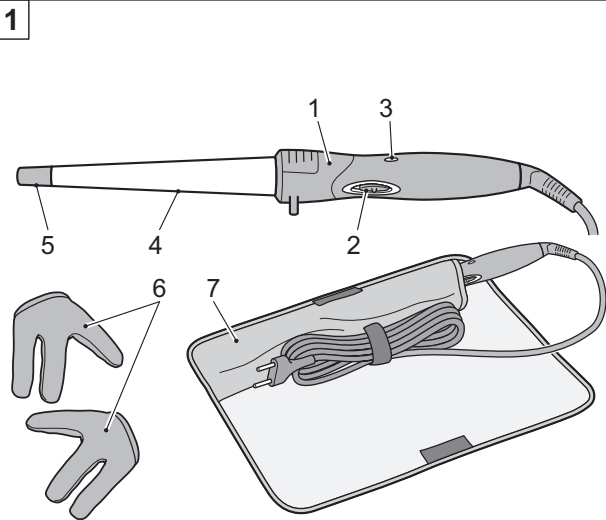

English

OPERATING INSTRUCTIONS - Type 641.02

Read these instructions carefully before using the appliance.

Available also on www.valera.com

WARNINGS

- **Important:** In order to guarantee additional protection, it is recommended that a differential breaker with an intervention current not greater than 30 mA is installed in the electrical system which feeds the device. For further information, contact a qualified electrician.
- Make sure the unit is perfectly dry before using it.
- **WARNING:** Do not use this appliance near bathtubs, showers, basins or other vessels containing water.
- This appliance can be used by children from 8 years of age and over, and by persons with limited physical, sensory or mental abilities or who lack the relevant experience and knowledge, if they are suitably supervised or have been educated to use the appliance safely and made aware of the associated risks.
- Do not allow children to play with the appliance.
- Children must not perform cleaning and maintenance procedures unless supervised.
- Prevent the hot surface on the unit from coming into contact with the face, neck or any other parts of the body. Use the unit, holding it by the handgrip.
- Allow the metal parts to cool down before touching them.
- Do not use your unit if it is not working properly. Do not try to repair this electrical unit yourself, rather contact an authorized technician. If the supply cord is damaged, it must be replaced by the manufacturer, its service agent or a similarly qualified person in order to avoid a hazard.
- When the appliance is used in a bathroom, unplug it after use since the proximity of water presents a hazard even when the appliance is switched off.
- Only connect this unit to alternating current and check that the mains supply voltage corresponds to that indicated on the unit.
- **Never immerse this unit in water or other liquids.**
- **Do not put this unit down where it could fall into water or other liquids.**
- **Do not try to pull any electrical appliance out when it has fallen into water - disconnect the plug from the power socket immediately.**

Mod. Nr.

Date of purchase Kaufdatum Date d'achat Data d'acquisto Fecha de adquisición Datum aankoop Data de compra Innkjøpsdato	Inköpsdatum Ostapáivámäärä Købsdato Eladás dátuma Datum prodaje Data cumpărării Data zakupu Ημερομηνία αγοράς	כתב אחריות Satin alma tarihi Datum nákupu Дата покупки Дата покупки Datum nabavke 购买日期 تاریخ الشراء تاریخ خرید
---	--	--

Name and full address of purchaser
Name und vollständige Anschrift des Käufers
Nom et adresse complète de l'acheteur
Nome e indirizzo completo dell'acquirente
Nombre y dirección completa del comprador
Naam en adres van de consument
Nome e endereço do cliente
Kjøperens fullstendige navn og adresse
Köparens namn och fullständig adress
Ostajan nimi ja täydellinen osoite
Køberens fulde navn og adresse
Vevő neve és teljes címe
Jméno a adresa zákazníka
Numele i adresa completă a compărătorului
Nazwisko oraz pełny adres kupującego
Όνομα, επώνυμο και πλήρης διεύθυνση του αγοραστή
תאריך קניה
Alicinin tam ismi ve adresi
Meno a celá adresa kupujúceho/zákazníka
Прізвище, ім'я, по батькові і повна адреса покупця
Фамилия/Имя и полный адрес покупателя
اسم المشتري وعنوانه الكامل
购买人完整姓名和地址
نام و نشانی کامل خریدار
Ime i adresa kupca
Ime i adresa dobavljača
Ime in naslov kupca
Име и целосна адреса на дистрибутер